

# Installation Manual

## Contents

- General description
- Accessories
- Installation
- Electrical connections
- Electric safety

Ascon TecnoLogic S.r.l.  
via Indipendenza 56,  
27029 - Vigevano (PV)  
Tel.: +39 0381 69871,  
Fax: +39 0381 698730  
www.ascontecnologic.com



## CANopen CPU module



## mod. CPU/CU02-00



### General description

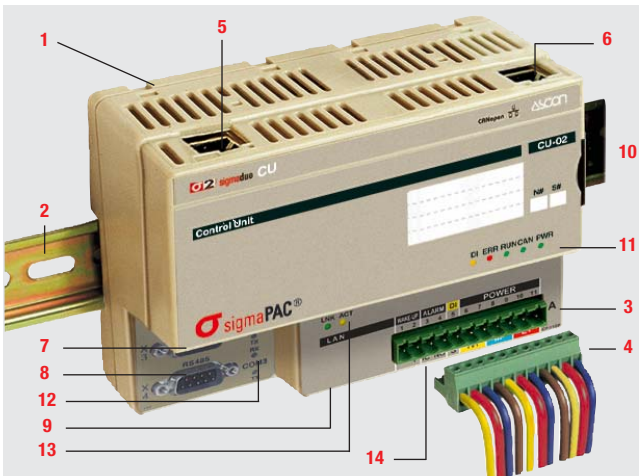

- 1 - Model identification label (on the back side of the module)
- 2 - DIN RAIL 35 x 7.5 (EN50022)
- 3 - Male 11 poles plug, pitch 5.0mm
- 4 - Female, 11 poles, fast snap-ON connectors, pitch 5.0mm, with screw or spring terminals to connect the power supply or the I/O (accessory)
- 5 - RJ45 plug to connect an RS 232 terminal for configuration purposes (labelled X1)
- 6 - RJ45 plug to connect the CANopen network (labelled X0)
- 7 - 9 poles Sub-D connector (labelled X3, COM 2) to connect a Modbus RTU bus (Master/Slave) using an RS 232 serial communication port
- 8 - 9 poles Sub-D connector (labelled X4, COM 3) to connect a Modbus RTU bus (Master/Slave) using an RS232/485 serial communication port. Optionally the two serial (COM3 and COM4) ports can be substituted by a Profibus ports (with 2 connectors)
- 9 - RJ45 plug to connect the Ethernet TCP/IP network for programming purposes or for the MODBUS through the TCP port (labelled X2).
- 10 - Removable and writable label to identify the connected I/O (TAG number)
- 11 - 5 status LEDs: identify the diagnostic and the module status
- 12 - 4 LED that display the communications status on the serial ports
- 13 - 2 LED to identify the Ethernet port status
- 14 - Slides to install an additional terminal block 2 x 11 poles (accessory)

### Installation

#### Dimensions (mm)

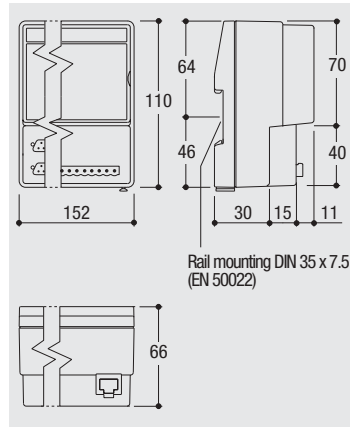

#### Operating conditions

Environmental condition	CE	Suggestion
Operating conditions	Temperature -10...+55°C	
	Humidity 5...95% Rh non condensing	
Special conditions	Temperature > 65°C	Use forced ventilation
	Humidity > 95% RH	Warm up
Forbidden conditions	Conducting atmosphere	Use filter
	Corrosive atmosphere	
	Explosive atmosphere	

#### Mounting position

- Mount the module vertically;
- In order to help the ventilation flow of air, respect the distances between modules and walls or other modules.

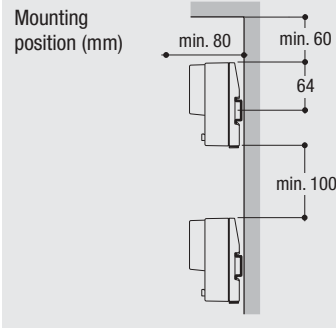

#### Mounting/removing the modules on/from the DIN rail

- 1 Close the spring slide, then clip the upper part of the module on the rail;
- 2 Rotate the module downwards till to the click;
- 3 Switch OFF the Power Supply  
Lower the spring slide by inserting a flat-blade screwdriver as indicated;
- 4 Turn and lift the module upwards.

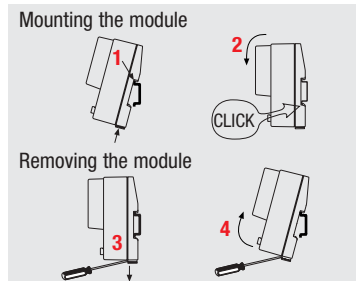

### Accessories

Power supply 75W - 3A/24 Vdc  
AP-S2/AL-DR75-24



11 poles connectors  
With screw terminals: AP-S2/SPINA-V11  
With spring terminals: AP-S2/SPINA-M11

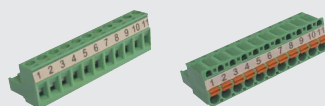

Field bus cables with RJ45 connectors  
140 mm: AP-S2/LOCAL-BUS76  
220 mm: AP-S2/LOCAL-BUS152



Power supply 120W - 5A/24Vdc  
AP-S2/AL-DR120-24



Additional terminal block  
AP-S2/TB-211-1

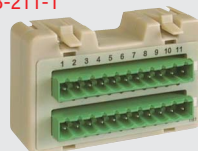

2 connectors with termination circuitry  
AP-S2/TERM-CAN



#### Hot swapping the I/O modules

Node ID and Baud rate of the new I/O module must already be correctly set. The procedure to minimize the CANbus disconnection time follows:

- 1 Remove all the cabled connectors from their plugs (item 4 in "General description" paragraph), do not extract the CANbus RJ45 connectors yet;
- 2 Remove the I/O module from the DIN rail;
- 3 Mount the new and already configured module on the DIN rail;
- 4 Extract the left side RJ45 connector from the module and insert it in the new module;
- 5 Extract the right side RJ45 connector from the module and insert it in the new module;
- 6 Insert all the cabled connectors in the new module.

## Electrical connections

### Terminals connections and plugs

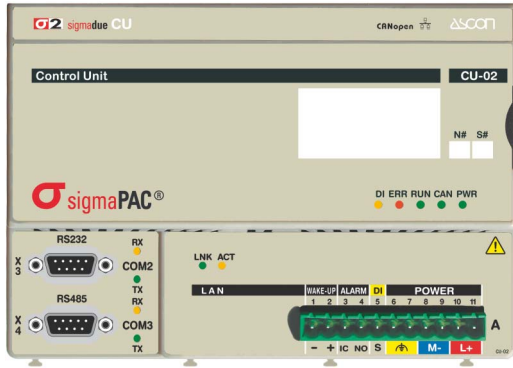

Pin	Label	Signals
A1, A2	- +	Wakes Up an external device
A3, A4	IC NO	Alarm Output
A5	S	Digital Input
A6, A7		Hearth terminals
A8, A9	M-	0V power supply terminals
A10, A11	L+	+24V power supply terminals

Description	Terminals	CAN Bus
Flexible cable section:	0.2...2.5 mm <sup>2</sup> AWG24...AWG12	CAT 5 UTP 8xAWG24
Stripped wire	Screw: 7mm Spring: 10mm	
Flat blade screwdriver	0.6 x 3.5 mm	RJ45 mounting tool
Tightening torque	0.5...0.6 Nm	

#### Technical data:

- Two 11 poles plugs, pitch 5.0 mm
- Made with self extinguishing material as required by UL94 V0 standard
- Overvoltage category/pollution degree II/2
- Max. load current/section 8A/2.5mm<sup>2</sup> at 65°C
- Test pulse voltage: 4 kVp.

- Please note that the maximum current capacity for each terminal is 8A
- Make sure that the overall current absorption (modules and field devices) matches the power supply
- In order to avoid excessive voltage drops, install the most power consuming modules closer to the power supply.

### Power supply

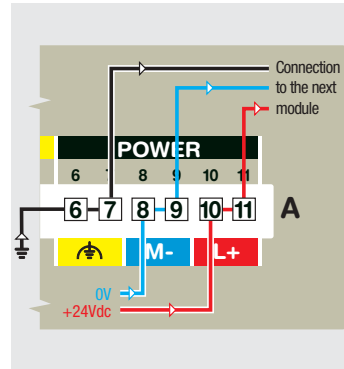

- 24Vdc (-15...+25%), 5W max.
- The power supply terminals A6 - A7, A8 - A9, A10 - A11 are internally connected; in this way it is possible to bring the power supply to other modules.

Functional earth terminal. This type of earthing does not protect against electrical shocks.

### Additional terminal block TB-211-1

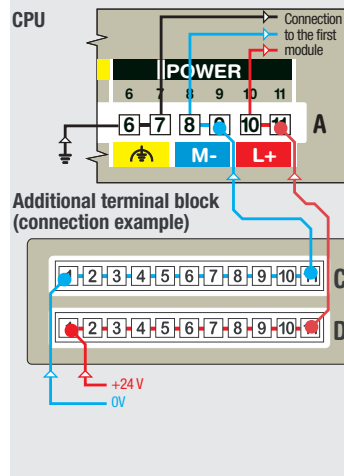

An additional terminal block can be installed on the CPU module using the two slides located in the lower part of the module case. The additional terminal block has no active components inside, only two 11 contacts connectors.

All the 11 contacts of each connector (C and D) are internally connected and can be used to make multiple connections (see the example).

### Digital Input Type II (EN61131-2)

#### Digital Input connection examples

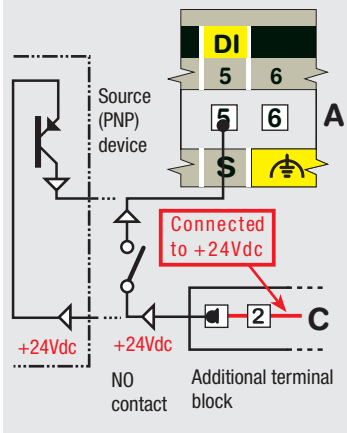

- Respect the polarity.
- When present the shield must be connected to a proper earth (at only one end);
- If the input device needs to be powered by the module, verify that the current consumption does not exceed the power supply limits;
- Connect the 0Vdc externally.
- DI is referred to M- of power supply

### Relay Alarm Output

#### Alarm output connection example

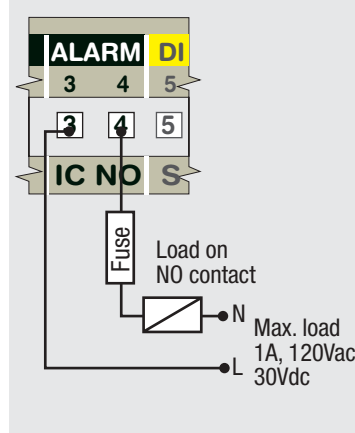

- Protect loads with fast type fuses;
- Contact ratings:
  - 1A at 120Vac/24Vdc resistive load;
  - Max. switched voltage: 120Vac/30Vdc;
  - Max. switched current 1A;
  - Max. switched power: 120VA/24W.

### Source Type (PNP) Wake Up Output

#### Wake up connection example

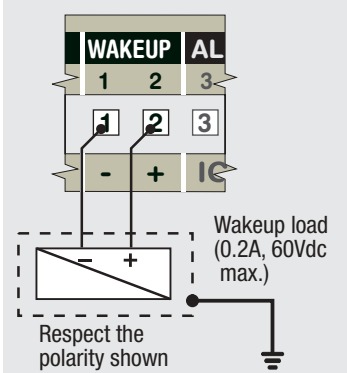

- Respect the polarity
- When present the shield must be connected to a proper earth (at only one end).

## Communications connections

On the CPU module are present all the communications ports. Connect the cable of the various interfaces as follows:

### CAN bus connector

The CAN bus connector is located in the upper side (on the right) of the CPU (item 6 in "general description" at page 1). Looking the hole of the plug the 8 contacts are arranged as illustrated in the draw.

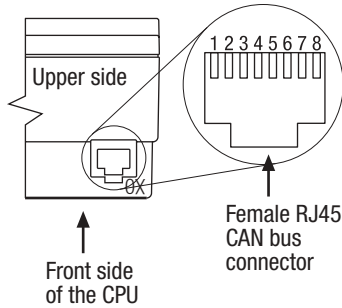

### RS232 Service Port connector

The RS232 Service Port can be used to configure the CPU and its devices using a dumb VT100 terminal. The RJ45 RS232 Service Port connector is located in the upper side (on the left) of the CPU (item 5 in "general description" at page 1). Looking the hole of the plug the 8 contacts are arranged as illustrated in the draw.

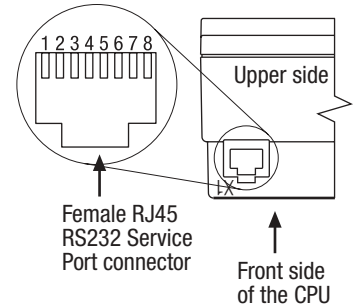

### CAN signals

Pin	Signal
1	CANH
2	CANL
3	GNDCAN
4	Reserved
5	Reserved
6	GNDSHLD (1)
7	GNDCAN
8	CANV+

(1) Shield to protect the communication cables.

### CAN connection

- 1 Install the CPU and the modules on the DIN rail (max. 60, up to 127 with repeaters)
- 2 Connect the modules mounted side by side using the standard cables (140/220 mm)
- 3 Connect the remote modules using cables with the proper length (see table)
- 4 As the CPU is internally terminated, install on the last CAN module a connector with the termination circuitry.

Maximum length of the fieldbus network:

Meters	Baud rate
2500	20 kbps
1000	50 kbps
500	125 kbps
250	250 kbps
100	500 kbps
50	800 kbps
25	1000 kbps

### RS232 Service Port signals

The signals present at the RJ45 connector of the RS232 Service Port are:

Pin	Signal
1	NC
2	NC
3	NC
4	GND
5	RX
6	TX
7	NC
8	NC

### RS232 Service Port connection

- 1 The RS232 cable must be shorter than 15 m.
- 2 The default configuration of the RS232 Service Port is:
  - Baud Rate: 9600 bps;
  - Data: 8 bit;
  - Stop bit: 1;
  - Parity: none;
  - Flow Control: none.

### Ethernet TCP/IP port connector

The Ethernet TCP/IP port RJ45 connector is located in the lower side of the CPU (item 6 in "general description" at page 1). Looking the hole of the plug the 8 contacts are arranged as illustrated in the draw.

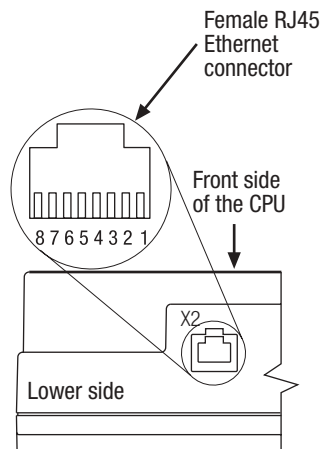

### RS232 expansion ports (option)

In the CPU can be installed up to 2 serial Expansion ports. When the expansion ports installed are RS232 compliant, the signals present at the sub D connector of the RS232 expansion Ports are:

Pin	Signal
1	CD
2	RX
3	TX
4	DTR
5	GND
6	DSR
7	RTS
8	CTS
9	RI

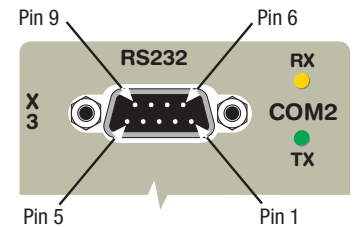

### Ethernet signals

The signals present on the RJ45 ethernet connector are those standard for all Ethernet TCP/IP connection.

To correctly connect the CPU to the programming computer, use an ethernet "cross cable" when the connection is direct (no HUB or network between the PC and the CPU); otherwise, if the Computer is not directly connected to the CPU, use a "direct cable" to connect the CPU to the HUB or to the network.

Pin	Signal
1	TX+
2	TX-
3	RX+
4	NC
5	NC
6	RX-
7	NC
8	NC

### RS485 expansion ports (option)

In the CPU can be installed up to 2 serial Expansion ports; one of them can be RS485 compliant (only in position X4), the signals present at the sub D connector of the RS485 expansion Port are:

Pin	Signal
1	NC
2	NC
3	NC
4	NC
5	GND
6	NC
7	Positive differential signal (D+)
8	Negative differential signal (D-)
9	NC

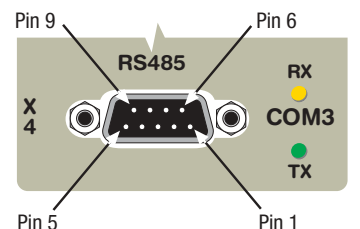

### 3 wire RS232 expansion port (option)

In position COM3 (connector X4) of the CPU can be installed a 3 wire RS232 serial Expansion port. When this expansion port is installed in the CPU the signals present at the sub D connector are:

Pin	Signal
1	NC
2	RX
3	TX
4	NC
5	GND
6	NC
7	NC
8	NC
9	NC

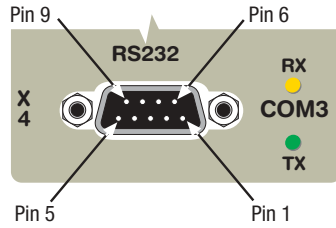

### Setting the internal DIP switches

- With the blade of a screwdriver, free the 8 slots (at the top and bottom of the CPU) in order to remove the rear cover from the rest of the housing;

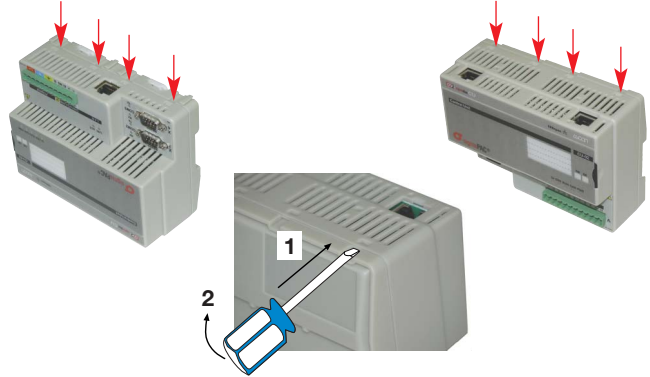

- Once the box of the CPU is open, locate the DIP switch block in the lower-right part of the CPU. The default position of the 4 switches is shown in the following image:

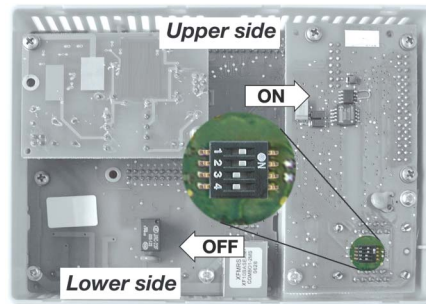

Position and description of the 4 microswitches:

- Line polarization Pull-Up (default: enabled = ON);
- Line polarization Pull-Down (default: enabled = ON);
- Not used;
- Line termination resistance (110Ω) (default: disabled = OFF).

The Pull-Up and Pull-Down line polarization switches must be enabled (or disabled) contemporaneously.

- After the switches has been set, the user can close the CPU rear cover:
  - The rear cover must be positioned in order to put the two slides which lock the box to the DIN rail in the lower part (look at the CPU front to identify the upper and the lower CPU).
  - After the two parts of the CPU have been aligned, press the two parts of the box in order to re-insert the 8 slots opened at the beginning of this setting procedure.



### PROFIBUS DP expansion port (option)

In the CPU can be installed also a PROFIBUS DP Expansion port, this port needs 2 sub D female connectors in positions X3 (OUT) and X4 (IN). The signals present on the 2 connectors are identical and can be found in the following table:

Pin	Signal
1	NC
2	NC
3	RxD/TxD-P (Rx/Tx data positive)
4	NC
5	DGND (DG = Data transmission potential (ground to 5V))
6	VP for termination resistance (+5V)
7	NC
8	RxD/TxD-N (Rx/Tx data negative)
9	NC

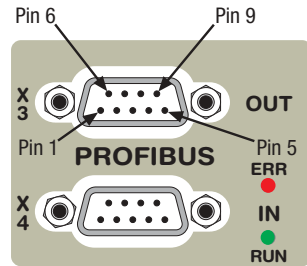

Near the Profibus connectors two LED are present with the following meanings:

LED	Condition	Description
Green	OFF	Node not active
	Blinking	Configuration phase active
Red	ON	Exchange data active
	OFF	No error
	ON	General error

## CE Electric safety and electromagnetic compatibility

**Class II instrument, rear panel mounting.**  
This instrument has been designed in compliance with:

**Regulations on electrical equipment:** according to regulations on the essential protection requirements in electrical equipment EN 61010-1

**Regulations on Electromagnetic Compatibility** according to:

- Regulations on RF emissions: EN61000-6-4 industrial environments;
- Regulation on RF immunity: EN61000-6-2 industrial equipment and system.

It is important to understand that it's responsibility of the installer to ensure the compliance of the regulations on safety requirements and EMC.

This controller has no user serviceable parts and requires special equipments and specialised engineers to be repaired. For this purpose, the manufacturer provides technical assistance and the repair service for its Customers. Please, contact your nearest Agent for further information.

All the information and warnings about safety and electromagnetic compatibility are marked with the  sign, at the side of the note.

### Before installing the module read the following instructions

#### Precautions



All wirings must comply with the local regulations

- The supply wiring should be routed away from the power cables
- Avoid to use electromagnetic contactors, power relays and high power motors nearby
- Avoid power units nearby, especially if controlled in phase angle
- Keep the low level sensor input wires away from the power lines and the output cables. If this is not achievable, use shielded cables on the sensor input, with the shield connected to earth.

#### Notes

- Make sure that the power supply voltage is the same indicated on the instrument label
- Switch ON the power supply only after all the electrical connections have been completed