

SMART UNIVERSAL SIGNAL CONDITIONER

ZTT-50/GD (SEM1700)

- > **DIRECT USB CONNECTION FOR CONFIGURATION**
- > **Rtd, THERMOCOUPLE, mV, V, mA and SLIDEWIRE INPUTS**
- > **ISOLATED UNIVERSAL VOLTAGE or CURRENT OUTPUT**
- > **DUAL c/o RELAY TRIP OUTPUTS WITH PROGRAMMABLE DELAY**
- > **UNIVERSAL AC DC POWER SUPPLY, 3 PORT ISOLATION**
- > **USER TRIM / USER MANUAL CONFIGURATION PUSH BUTTONS**



INTRODUCTION

The ZTT-50/GD is a new generation DIN rail mounted universal signal conditioner. It has been designed to accept most common process and temperature sensor inputs and provide the user with a programmable current or voltage output signal plus dual trip relays with a programmable delay function. Isolation is provided between input, outputs and supply. All temperature ranges are linear to temperature. Both input and output loop excitation is provided as well as a fully universal power supply.

Designed for ease of use, our latest USB interface is fitted for quick and easy configuration. Just connect a standard USB cable between the ZTT-50/GD and your PC. Using our free configuration software, your PC will automatically upload the existing configuration data and guide you through any changes you wish to make. To further help save time, the ZTT-50/GD does not need to be wired to a power supply during the configuration process, it is powered via the USB interface from your PC.

The following parameters are configurable:-

INPUT TYPE	SCALE / RATE	ANALOGUE OUTPUT	TRIP OUTPUTS	USER TRIM OPTIONS
RTD Pt100 .00385 (IEC) Pt100 .00391 (IPTS-68) Pt100 .00392 (IPTS-68) Pt100 .00393 (ITS-90) Ni100 .00618 (DIN) Ni120 .00672 (Nickel A) Cu100 .00427 Cu53	$^{\circ}\text{C} / ^{\circ}\text{F} / ^{\circ}\text{K}$ Update Rate	Current (4 to 20) mA Preset (0 to 20) mA Preset User Programmable Range	TRIP 1(A) / TRIP2 (B) Setpoint Hysteresis High AI Low AI High Con Low Con Off On Delay Off Delay	1. Off 2. Trim 3. Push Button Configuration
T/C K, J, E, N, T, R, S, L,U, B, C(W5), D(W3), G(W)		Voltage (0 to 10) V Preset User Programmable Range Fault Condition Up Scale Down Scale User Programmable Setting		
SLIDE WIRE > 1K	Process Variable Scaling	Output damping rise Output damping fall		
CURRENT (mA) ± 30 mA (4 to 20) mA Capability	Update Rate			
VOLTAGE ± 50 mV ± 200 mV ± 1 V ± 10 V				
TAG ID.	Upto 15 Characters can be used			

SMART UNIVERSAL SIGNAL CONDITIONER

SPECIFICATION @20 °C

TEMPERATURE INPUTS

INPUT	RANGE	ACCURACY	STABILITY WITH TEMPERATURE	
Thermocouples				
K	(-200 to 1370) °C (-320 to 2498) °F	1 Reading / Second ± 0.5 °C + (0.1 % of FRS)	±0.05 % FSR/°C	
J	(-200 to 1200) °C (-320 to 2190) °F			
E	(-200 to 1000) °C (-320 to 1832) °F			
N	(-180 to 1300) °C (-292 to 2372) °F	4 Readings / Second ± 1.0 °C + (0.1 % of FRS)	±0.08 % FSR/°C	
T	(-200 to 400) °C (-320 to 750) °F	10 Readings / Second ± 2.0 °C + (0.1 % of FRS)	±0.15 % FSR/°C	
R *1 *2	(-10 to 1760) °C (-148 to 3200) °F		±0.10 % FSR/°C	
S *1 *2				
L			±0.08 % FSR/°C	
B *1 *2			±0.10 % FSR/°C	
U			±0.08 % FSR/°C	
C(W5) *2			(0 to 2300) °C (32 to 4200) °F	±0.05 % FSR/°C
D(W3) *2				
G(W) *2				
RTD				
Pt100.00385 (IEC)	(-200 to 850) °C (-320 to 1560) °F	1 Reading / Second ± 0.15 °C + (0.05 % of FRS)	±0.015 % FSR / °C *3	
Pt100 .00391 (IPTS-68)	(-200 to 630) °C (-320 to 1160) °F			
Pt100 .00392 (IPTS-68)		4 Readings / Second ± 0.5 °C + (0.1 % of FRS)		
Pt100 .00393 (ITS-90)	(-200 to 960) °C (-320 to 1760) °F			
Ni 100 .00618 (DIN)				(-60 to 180) °C (-76 to 320) °F
Ni120 .00672 (Nickel A)				
Cu100 .00427	(-80 to 260) °C (-112 to 460) °F	10 Readings / Second ± 1.0 °C + (0.1 % of FRS)		
Cu 53 (GOST)	(-50 to 180) °C (-58 to 320) °F			

Key rdg = reading; FSR = Full Scale range ; *1 Only over the range (800 to 1600) °C, *2 cold junction tracking range(0 to 70) °C , *3 Ambient (-10 to 50) °C

Impedance (Thermocouple)	1 MΩ
Open Circuit sensor bias	0.2 uA
Cold junction range	(-20 to 70) °C
Cold Junction Accuracy	± 0.5 °C
Cold Junction Tracking	± 0.05 °C
RTD Connection	2 or 3 wire
RTD Lead Resistance	20 Ω Max
RTD Lead effect	0.015 °C / Ω.
RTD Excitation Current	< 1 mA
Update Rate (Resolution)	1 readings / second (16 Bits) ; 4 Readings / Second (14 Bits) ; 10 readings / Second (12 Bits)
Isolation	500 V to output : 3750 V to supply and Trips
Display	OK LED blinks when signal is within range, Continuously on in fault

SMART UNIVERSAL SIGNAL CONDITIONER

PROCESS INPUTS

INPUT	RANGE	ACCURACY @ 20 °C	STABILITY WITH TEMPERATURE
50 mV	± 50 mV (Max ± 75 mV)	1 Reading / Second	± 0.04 % FSR / °C
200 mV	±200 mV (Max ± 230 mV)	±0.04% + (0.1% of FRS)	
1 V	± 1 V (Max ± 1.3 V)	4 Readings / Second	± 0.05 % / °C
10 V	± 10 V (Max ± 11 V)		
mA	± 25 mA (Max ±30 mA)	10 Readings / Second	± 0.025 % FSR / °C
Slide Wire	(0 to 100) % (1 to 1000) KΩ pot		
Ohms	(20 to 400) Ω Max (0 to 480) Ω		

Key - rdg = reading, FSR = Full Scale range

Voltage Input Impedance	1 MΩ
Current Input Impedance	20 Ω
Slide Wire Input Range	1 KΩ to 1000 KΩ Pot
Resistance Connection	2 or 3 Wire
Isolation	500 V to output : 3750 V to supply and Trips
Update Rate (Resolution)	1 readings / second (16 Bits) ; 4 Readings / Second (14 Bits) ; 10 readings / Second (12 Bits)

CURRENT OUTPUT

	RANGES mA			Fault /Error Signal mA		
	Min	Max	Min Span	Up	Down	User
(4 to 20) mA	4.0	20.0	-	22.5	3.8	(0.0 to 25) mA
(0 to 20) mA	0.0	20.0	-			
USER	0.0	24.0	0.5			

Type	Two wire current sink; or two wire current source
Supply in sink mode	(11 to 30) V dc , 24 V nominal
Max loop load	Sink mode loop load of 600 Ω @ 24 V ; Source mode 550 Ω
Response time	< 500 ms to reach 95 % of final value ; Start up time < 3 s
Calibration Accuracy	± 5 uA
Loop Effects	Loop ripple 0.03 % of FSR;
Supply sensitivity	Supply ripple rejection < ± 5 uA error @ 1 V rms 50 Hz ripple
Protection	Reverse connection and over-voltage protection. Max over voltage current 100 mA.
Isolation	500 V to input : 3750 V to supply and Trips
User Trim Options	1. Off (Locked) 2. Push button user trim at both ± 10 % of zero and ± 10 % of span 3. Manual Push Button range configuration
Current Output Damping	Programmable rise and fall (0 to 250) seconds, for a (0 to 20) mA swing.
Stability	± 5 uA / °C

VOLTAGE OUTPUT

	RANGES V			Fault /Error Signal V		
	Min	Max	Min Span	Up	Down	User
(0 to 10) V	0.0	10.0	-	11.5	0.0	(0.0 to 13)
USER	0.0	12.0	0.5			

Type	Voltage generated across 500 Ω resistor
Min Load	10 KΩ User Configurable correction for Load.
Response time	< 500 ms to reach 95 % of final value ; Start up time < 3 s
Calibration Accuracy	± 5 mV
Isolation	500 V to input : 3750 V to supply and Trips
User Trim	Push button user trim at both zero and span
Voltage Output Damping	Programmable rise and fall (0 to 250) seconds, for a (0 to 10) V swing.
Stability	± 1mV / °C

SMART UNIVERSAL SIGNAL CONDITIONER

TRIP OUTPUTS

Type	Dual Form C relay contacts
Contact rating	(240 V ac rms @ 1 A ; 30 V dc @ 1 A) Resistive Load
Trip Type	Individual trips 1 (A) & 2 (B) high or low level, full range setpoint plus adjustable Hysteresis
Ranges	Setpoint programmed on units, covering full range of input.
Hysteresis	Set in units.
Isolation	To any other port 3750 V
Delay	Programmable on / off delay (0 to 250) seconds for each trip.

SUPPLY

Range	(20 to 240) V DC, (20 to 240) V AC 50/60 Hz
Power	3 W max
Protection	Internal fuse , Over Voltage
Isolation	Supply to any port 3750 V

GENERAL

Ambient	Operating (-20 to 70) °C (10 to 95) % RH non condensing. Storage (-40 to 85) °C
Approvals	CE tested to BS EN 61326 ; BS EN 61010_1

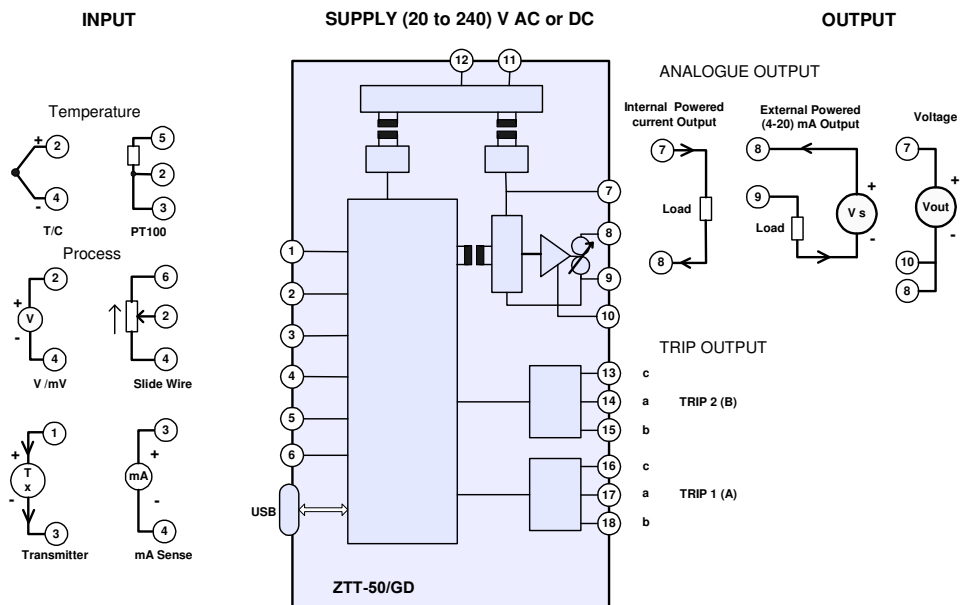

MECHANICAL

(Dimensions in mm)

