

Pneumatische Stellantriebe

Pneumatic Actuators

Servomoteurs pneumatiques

6100-7010



Baureihen
Series
Séries

- ST 6115
- ST 6135
- ST 6160



Spezialanwendungen
Special applications
Applications spéciale

- ST 6135.B6-__-C5-M
- ST 6135.B6-__-OX

- ST 6160.A6-__-C5-M
- ST 6160.A6-__-OX

Pneumatische Stellantriebe für Regel- und Absperrventile

- TÜV geprüft als Stellgerät mit Sicherheitsfunktion nach DIN EN 14597:2005-12 für Wasser und Wasserdampf in heiztechnischen Anlagen
- Umkehrbare Wirkungsrichtung
- Hub max. 60 mm
- Zuluftdruck max. 6 bar
- Stellkraft max. 10 kN
- Anbau von Stellungsreglern direkt, mit integrierter Luftzuführung, möglich
- Spezialanwendungen möglich
 - C5-M Seeluftbeständig
 - OX Für Sauerstoffbetrieb geeignet

Pneumatic actuators for control and on/ off valves

- Approved by German Technical Inspectorate (TÜV) as safety functional device for steam and water in heating systems.
- Reversible direction of action
- Stroke max. 60 mm
- Max air supply 6 bar
- Actuating force max. 10 kN
- Mounting of positioner with internal air supply

- Special applications possible
 - C5-M Marine air resistant
 - OX For oxygen as operating medium

Servomoteurs pneumatiques pour vannes de régulation et d'arrêt

- Agrément TÜV comme soupape de commande sur circuits d'eau et de vapeur dans des installations thermiques nécessitant une fonction de sécurité
- action réversible possible
- course max. 60 mm
- pression d'air auxiliaire 6 bars
- force max. 10 kN
- Installation du positionneur en direct, alimentation d'air commande interne
- Applications spéciale possible
 - C5-M Résiste à l'environnement air marin
 - OX Fonctionnement avec l'oxygène possible

Regeltechnik Kornwestheim GmbH
Max-Planck-Strasse 3
70806 Kornwestheim
GERMANY

Telefon +49 7154 1314-0
Telefax +49 7154 1314-333
Internet www.rtk.de
E-Mail: info@rtk.de

RTK[®]
REGELTECHNIK
KORNWESTHEIM
A division of CIRCOR International, Inc.

Choose the Original
Choose Success!

Technische Daten / Technical specification / Caractéristiques techniques

Type / type / type	ST 6115		ST 6135		ST6160	ST 6160	
	.A6-3S	.C6-4S	.B6-2G	.B6-6G	.A6-6G	.C6-3G	.C6-7G
Membranfläche / diaphragm area / surface membrane	120 cm ²		280 cm ²		530 cm ²	530 cm ²	
Federbereich / spring range / plage ressort (bar)	0,9..2,0	0,8-2,4	0,2..1,0	0,8..3,0	0,8..2,8	0,3..1,3	0,7..3,0
Hub / stroke / course	20 mm	25 mm	35 mm		40 mm	60 mm*	
Zuluftdruck / operating pressure / pression d'air commande [bar]	min. 2,2	min. 2,6	min. 1,2	min. 3,2	min. 3,0	min. 1,5	min. 3,2
	Max. 6						
Volumen Antrieb / volume actuator / volume servomoteur	0,4 L _N		1,7 L _N		2,8 L _N	3,6 L _N	
Umgebungstemperatur / ambient temperature / température ambiante	-40...80 °C					-20...80 °C	
Lackierung / coating / peinture	Kunstharz/ acrylic/ polyuréthane						
Gewicht / weight / poids	3 kg		5 kg		12,5 kg	14 kg	
Anschluss / air connection / raccordement	¼"NPT Innengewinde ¼"NPT taroudage ¼"NPT						
Einbaulage / mounting position / position de montage	beliebig any position indifférente						

*50 mm für Wirkrichtung « öffnen »; Federbereich reduziert
*50 mm for direction of action « open »; spring range reduced
*50 mm pour action « ouvrir »;plage ressort réduit

Zusätzliche Ausstattung / Optional accessories / Accessoires supplémentaires

Handverstellung / manual operation/ Commande manuelle	Oben / on top / sur le dessus		
Endschalter / limit switches / contacteur de course	Schaltleistung 400 V, 6A, Schutzart IP 65 rating 400 V, 6A, protection IP 65 puissance de coupure 400V, 6 A, protection IP 65		
3/2-Wege-Magnetventil / solenoid valve / electro- vanne	24 VDC, 24 V, 115 V, 230 V 50,60 Hz	Anschluß G ¼ connection G ¼ raccordement G ¼	
Stellungsregler / positioner / positionneur	Typ / type / type	Eingang / Input / entrée	
	SR P981 SR I990 SR 6137 SR 6136 (Sipart) SR TZIDC	0,2..1,0 bar 4..20 mA 4..20 mA 4..20 mA 4..20 mA	max 6 bar 2-Leiter/ wire / fils 3-Leiter / wire / fils 2/3/4-Leiter / wire / fils 2-Leiter / wire / fils Ri = 300 Ohm Ri = 175 Ohm Ri = 500 Ohm Ri = 50 Ohm

Sonstige zusätzliche Ausstattungen auf Anfrage / Other options available on request Autres options sur demande

Wichtiger Hinweis

Die Sicherheitsfunktion nach DIN EN 14597:2005-12 ist nur in Verbindung mit einem Steuerventil möglich, welches die Anforderung nach der genannten Norm erfüllt.

Des Weiteren benötigt der Antrieb in Verbindung mit der Zulassung nach DIN EN 14597:2005-12 für den störungsfreien Betrieb trockene, nicht geölte Instrumentenluft

- Feststoffgehalt ≤30µm
- Drucktaupunkt 20°C unter der Umgebungstemperatur

Important remark:

The safety function acc. DIN EN 14597:2005-12 is only possible in combination with a pilot valve which fulfills the requirements of the above mentioned directive.

Furthermore the actuator needs, in relation with an approval acc. to this directive, for a failure-free service, dry, unoled instrument air.

- solids content ≤ 30 µm
- pressure condensation point 20 °C under the ambient temperature

Renseignement important:

La fonction de sécurité selon la DIN EN 14597:2005-12 est uniquement possible avec une vanne de contrôle, qui satisfait les exigences de la directive mentionné en haut.

En outre, en relation avec un agrément selon cette directive DIN EN 14597:2005-12 et pour un fonctionnement sans arrêt, l'actionneur à besoin de l'air d'instrument sec et non-lubrifié

- corps solides ≤ 30 µm
- point de rosée de l'air comprimé 20 °C en-dessous de la température ambiante

Regeltechnik Kornwestheim GmbH
Max-Planck-Straße 3
70806 Kornwestheim
GERMANY

Telefon +49 7154 1314-0
Telefax +49 7154 1314-333
Internet www.rtk.de
E-Mail: info@rtk.de



REGELTECHNIK
KORNWESTHEIM

A division of CIRCOR International, Inc.

Maßblatt / dimension sheet / Encombrement

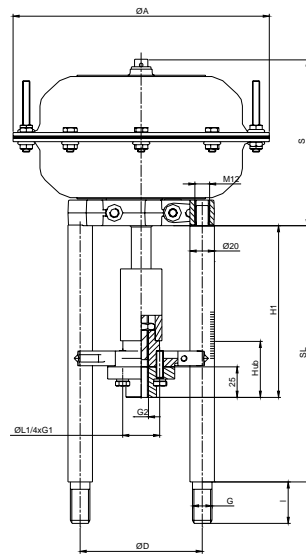

ST 6115_, ST 6135_, ST 6160_

Typ	Hub / stroke / course	H 1	SL		ØD	G	I	ØL1	G1	G2	ØA	S
ST 6115	20 / 25	140	211	2 St.	100	M16	34	43	M6	M12	162	116 / 122
ST 6135	35	140	211	2 St.	100	M16	34	43	M6	M12	210	136
ST 6160	40 / 60	143 / 166	211 / 231	2 St.	100	M16	34	43	M6	M12	310	166 / 186

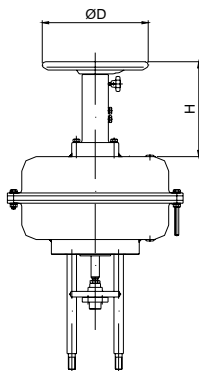

Typ	H	ØD
ST 6115-__	219	250
ST 6135-__	219	250
ST 6160-__	357	315

Handverstellung / manual operation / commande manuelle



Regeltechnik Kornwestheim GmbH
Max-Planck-Straße 3
70806 Kornwestheim
GERMANY

Telefon +49 7154 1314-0
Telefax +49 7154 1314-333
Internet www.rtk.de
E-Mail: info@rtk.de



Choose the Original
Choose Success!

**REGELTECHNIK
KORNWESTHEIM**
A division of CIRCOR International, Inc.

ST 6115 A6-6S



ST 6115 C6-4S



Regeltechnik Kornwestheim GmbH
Max-Planck-Straße 3
70806 Kornwestheim
GERMANY

Telefon +49 7154 1314-0
Telefax +49 7154 1314-333
Internet www.rtk.de
E-Mail: info@rtk.de



Choose the Original
Choose Success!

**REGELTECHNIK
KORNWESTHEIM**
A division of CIRCOR International, Inc.

ST 6135 B6-6G



ST 6135 B6-OX
für Sauerstoffbetrieb



Regeltechnik Kornwestheim GmbH
Max-Planck-Straße 3
70806 Kornwestheim
GERMANY

Telefon +49 7154 1314-0
Telefax +49 7154 1314-333
Internet www.rtk.de
E-Mail: info@rtk.de



**REGELTECHNIK
KORNWESTHEIM**
A Division of CIRCOR International, Inc.

ST 6160 A6



ST 6160 C6-3G



ST 6160 A6-6G-OX
für Sauerstoffbetrieb

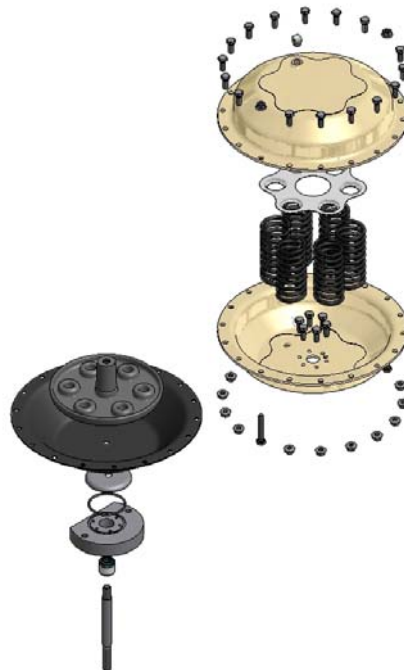

Ersatzteilliste / spare parts list / Liste de pièces détachées

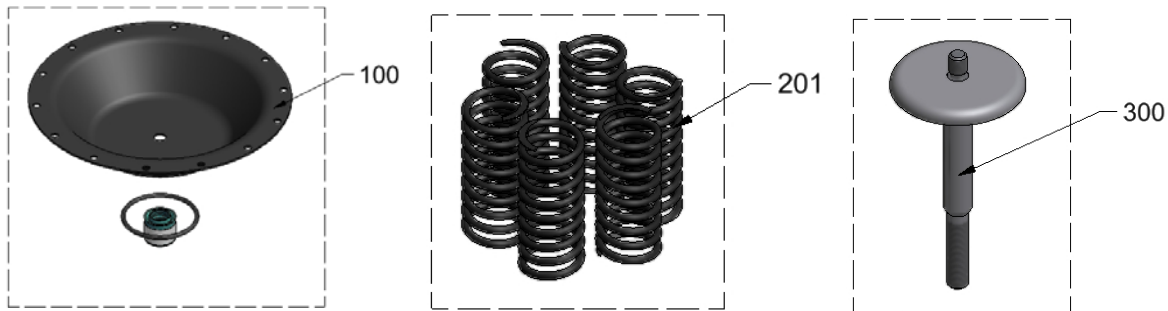

Pos	Material	Order-No.	D	GB	FR
100		CMEM15A60009 CMEM35B60009 CMEM35B60019 CMEM60A60009 CMEM60A60019	Membrangruppe ST6115 ST6135 bis 07/10 ST6135 ab 08/10 ST6160 bis 07/10 ST6160 ab 08/10	diaphragm assembly ST6115 ST6135 till 07/10 ST6135 from 08/10 ST6160 till 07/10 ST6160 from 08/10	groupe membrane ST6115 ST6135 à 07/10 ST6135 en 08/10 ST6160 à 07/10 ST6160 en 08/10
201		CFER15A63S09 CFER15C64S09 CFER35B62G09 CFER35B66G09 CFER60C63G09 CFER60C67G09	Druckfeder ST6115.A6-3S ST6115.C6-4S ST6135.B6-2G ST6135.B6-6G ST6160.C6-3G ST6160.C6-7G	Spring ST6115.A6-3S ST6115.C6-4S ST6135.B6-2G ST6135.B6-6G ST6160.C6-3G ST6160.C6-7G	Ressort ST6115.A6-3S ST6115.C6-4S ST6135.B6-2G ST6135.B6-6G ST6160.C6-3G ST6160.C6-7G
300		CSTK61150009 CSTK6160A609 CSTK6160C609	Kolbenstangen -Gruppe ST6115 / ST6135 ST6160.A6 ST6160.C6	Rod group ST6115 / ST6135 ST6160.A6 ST6160.C6	Group tige du piston ST6115 / ST6135 ST6160.A6 ST6160.C6

Technische Änderung vorbehalten / Subject to technical alteration / Sous réserve de modifications techniques